



Part no.: 50120426
BTU 200M.5-D12
Mounting system

Figure can vary

Contents

- Technical data
- Dimensioned drawings
- Accessories



Technical data

Basic data

Contains	2x position washers 2x M3 mounting nut 2x M3 x 18 screw
Suitable for	5 series sensors 28 series sensors 25B series sensors 3B series sensors 18 series sensors 55 series sensors

Mechanical data

Standard designation, stainless steel mounting device	V2A
Design of mounting device	Mounting system
Type of fastening, at system	For 12 mm rod
Type of fastening, at device	Screw type
Type of mounting device	Adjustable Clampable Turning, 360°
Mounting device material	Stainless steel

Classification

eCl@ss 8.0	27279202
eCl@ss 9.0	27273701

Dimensioned drawings

All dimensions in millimeters

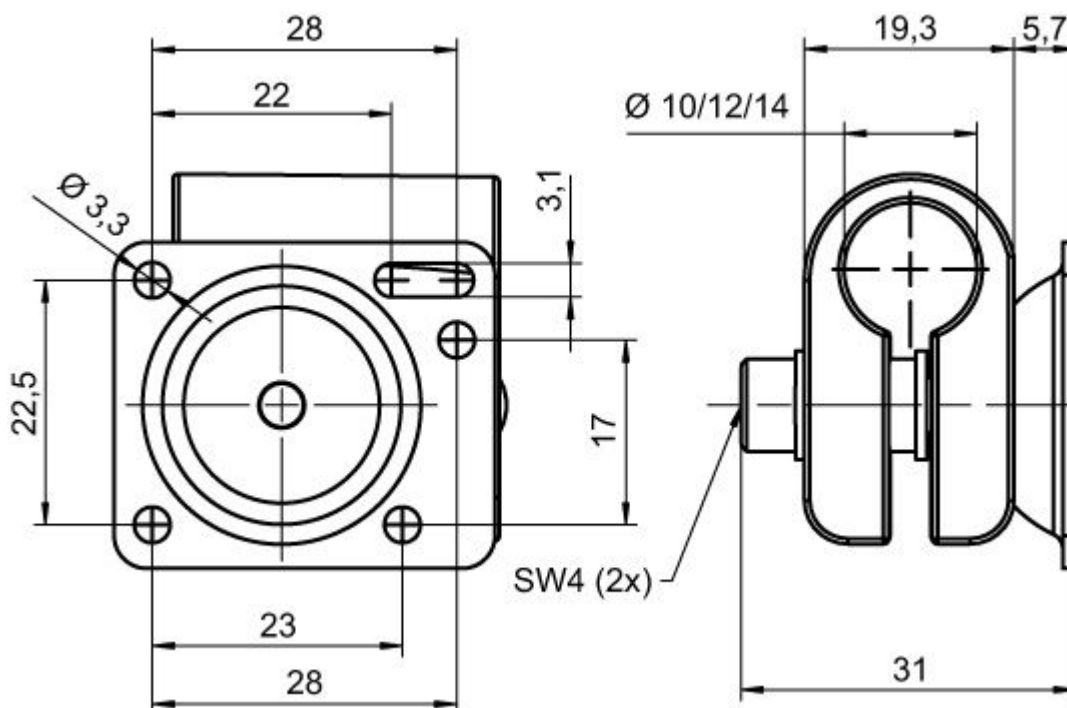

Part no.: 50120426 – BTU 200M.5-D12 – Mounting system

Accessories

Micro-triad-type reflectors

	Part no.	Designation	Article	Description
	50040895	MTKS 20x20	Reflector	Design: Rectangular Reflective surface: 20 mm x 20 mm Material: Plastic Base material: Plastic Chemical designation of the material: PMMA8N Fastening: Through-hole mounting, Adhesive